

PHILIPS

Fortimo

LED

Fortimo SLM PW
1203 L09 1619 G7

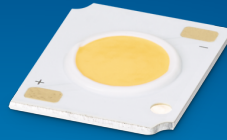

Datasheet

Experience bright and vivid colors

Fortimo LED SLM PW 1203 L9 1619 G7

Fortimo LED SLM Gen7 continues to focus on the combination of Quality of Light and performance. By offering the CoB separate from the holder, even more flexibility in possible system combinations and specifications is achieved. This results in an extensive portfolio of lumen ranges, CCTs and spectra. Please also check the online Easy Design-in Tool for your perfect system combination (www.easydesignintool.com)

Key features and benefits

- Best quality of light available for all applications
- Extensive range of CCTs
- Small LES for narrow beam angles and small reflector designs
- Flexibility to select a different lumen output between 800 and 10000 lm
- State of the art Chip-on-Board (CoB) technology, enabling highest system efficacy
- System proposition (CoB + Holder + driver)
- Flexibility to optimize luminaire performance (lm/W or high lm output)
- Xitanium window drivers with SimpleSet for maximum flexibility
- Mini drivers for smallest possible luminaire designs
- Five years system warranty with over 50,000 hours lifetime
- Instant full light

March 2018

Ordering data

Commercial product name	EOC	12NC	Box quantity
Fortimo SLM C 830 PW 1203 L09 1619 G7	8718696 845547 00	9290 015 84606	20
Fortimo SLM C 930 PW 1203 L09 1619 G7	8718696 845578 00	9290 015 84706	20
Fortimo SLM C 935 PW 1203 L09 1619 G7	8718696 845608 00	9290 015 84806	20
Fortimo SLM C 940 PW 1203 L09 1619 G7	8718696 845639 00	9290 015 84906	20

Not all products are globally available by default.

Please contact your local Philips Lighting representative for local availability and activation.

Drive currents

Parameter	Nominal*	Life**	Max***	Unit
Fortimo SLM PW 1203 L09 1619 G7	300	510	510	mA

Module temperatures

Parameter	Nominal*	Life**	Max***	Unit
T _c (case temperature at T _c point)	85	85	95	°C

* Nominal value at which typical performance is specified

** Value at which life time is specified

*** Maximum value for safe operation, do not operate above this value

Optical characteristics - table per color (CCT)

Fortimo SLM C 830 PW 1203 L09 1619 G7

Parameter	Min	Typ	Max	Unit
Luminous flux	1359	1510	1661	lm
Module efficacy	132	146		lm/W
Correlated color temperature (CCT)		3000		K
Color coordinates (CIEx, CIEy)		(0.422, 0.386)		-
Color consistency			3	SDCM
CRI	80	82		
Photobiological safety			RG1 unlimited	
Energy efficiency label		A++		

Measurement precision for flux +/- 5%. Measurement precision for efficacy +/- 6%. Measurement precision for x, y +/- 0.005. Measurement precision for CRI 1.5

Operation point	830	lm	lm/W
80% I-nom 240mA	Tc 25 °C	1344	162
	Tc-nom 85 °C	1240	153
	Tc-max 95 °C	1219	151
I-nom 300mA	Tc 25 °C	1646	156
	Tc-nom 85 °C	1510	146
	Tc-max 95 °C	1483	144
I-life 510mA	Tc 25 °C	2605	137
	Tc-nom 85 °C	2360	127
	Tc-max 95 °C	2311	125

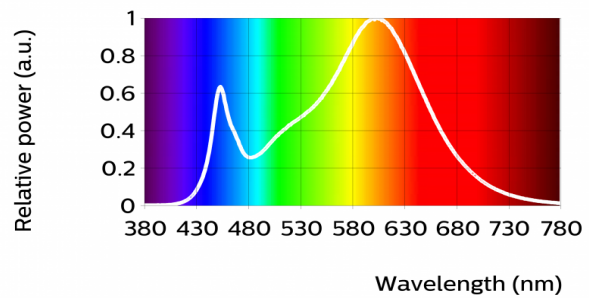

R1	R2	R3	R4	R5	R6	R7	R8	R9	R10	R11	R12	R13	R14
83	95	92	80	84	93	80	58	10	88	79	79	86	96

Fortimo SLM C 930 PW 1203 L09 1619 G7

Parameter	Min	Typ	Max	Unit
Luminous flux	1152	1280	1408	lm
Module efficacy	112	124		lm/W
Correlated color temperature (CCT)		3000		K
Color coordinates (CIEx, CIEy)		(0.422, 0.386)		-
Color consistency			3	SDCM
CRI	90	92		
Photobiological safety			RG1 unlimited	
Energy efficiency label		A+		

Measurement precision for flux +/- 5%. Measurement precision for efficacy +/- 6%. Measurement precision for x, y +/- 0.005. Measurement precision for CRI 1.5

Operation point	930	lm	lm/W
80% I-nom 240mA	Tc 25 °C	1140	137
	Tc-nom 85 °C	1051	130
	Tc-max 95 °C	1034	128
I-nom 300mA	Tc 25 °C	1396	132
	Tc-nom 85 °C	1280	124
	Tc-max 95 °C	1257	122
I-life 510mA	Tc 25 °C	2208	116
	Tc-nom 85 °C	1999	108
	Tc-max 95 °C	1957	106

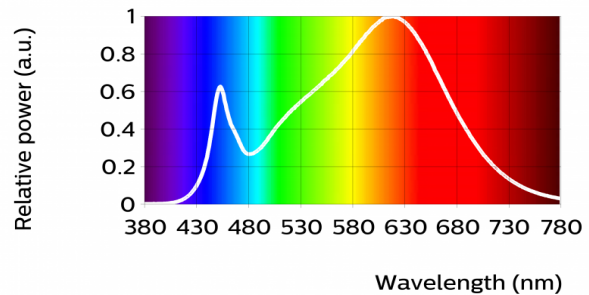

R1	R2	R3	R4	R5	R6	R7	R8	R9	R10	R11	R12	R13	R14
93	97	97	91	93	95	90	80	58	93	91	83	95	99

Fortimo SLM C 935 PW 1203 L09 1619 G7

Parameter	Min	Typ	Max	Unit
Luminous flux	1215	1350	1485	lm
Module efficacy	118	131		lm/W
Correlated color temperature (CCT)		3500		K
Color coordinates (CIEx, CIEy)		(0.398, 0.376)		-
Color consistency			3	SDCM
CRI	90	92		
Photobiological safety			RG1 unlimited	
Energy efficiency label		A++		

At currents higher than 504 mA the module might be classified as RG2

Measurement precision for flux +/- 5%. Measurement precision for efficacy +/- 6%. Measurement precision for x, y +/- 0.005. Measurement precision for CRI +/- 1.5

Operation point	935	lm	lm/W
80% I-nom 240mA	Tc 25 °C	1202	145
	Tc-nom 85 °C	1109	137
	Tc-max 95 °C	1090	135
I-nom 300mA	Tc 25 °C	1472	139
	Tc-nom 85 °C	1350	131
	Tc-max 95 °C	1326	129
I-life 510mA	Tc 25 °C	2329	123
	Tc-nom 85 °C	2109	113
	Tc-max 95 °C	2065	112

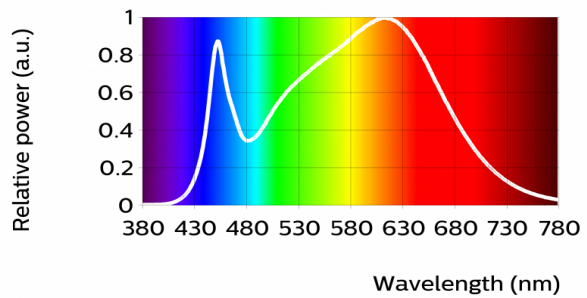

R1	R2	R3	R4	R5	R6	R7	R8	R9	R10	R11	R12	R13	R14
93	96	97	91	92	93	92	82	59	89	91	77	94	98

Fortimo SLM C 940 PW 1203 L09 1619 G7

Parameter	Min	Typ	Max	Unit
Luminous flux	1251	1390	1529	lm
Module efficacy	121	135		lm/W
Correlated color temperature (CCT)		4000		K
Color coordinates (CIEx, CIEy)		(0.374, 0.364)		-
Color consistency			3	SDCM
CRI	90	92		
Photobiological safety			RG1 unlimited	
Energy efficiency label		A++		

At currents higher than 410 mA the module might be classified as RG2

Measurement precision for flux +/- 5%. Measurement precision for efficacy +/- 6%. Measurement precision for x, y +/- 0.005. Measurement precision for CRI +/- 1.5

Operation point	940	lm	lm/W
80% I-nom 240mA	Tc 25 °C	1238	149
	Tc-nom 85 °C	1142	141
	Tc-max 95 °C	1122	139
I-nom 300mA	Tc 25 °C	1515	143
	Tc-nom 85 °C	1390	135
	Tc-max 95 °C	1365	133
I-life 510mA	Tc 25 °C	2398	126
	Tc-nom 85 °C	2172	117
	Tc-max 95 °C	2127	115

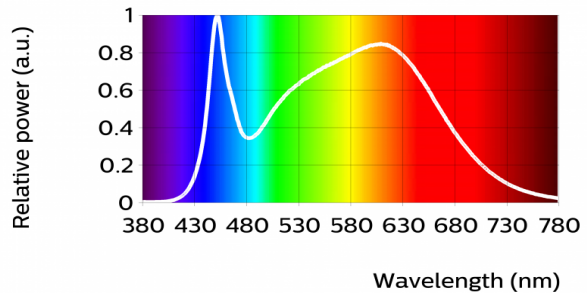

R1	R2	R3	R4	R5	R6	R7	R8	R9	R10	R11	R12	R13	R14
92	96	96	91	92	92	92	83	60	88	90	72	94	97

Beam shape

Bare CoB

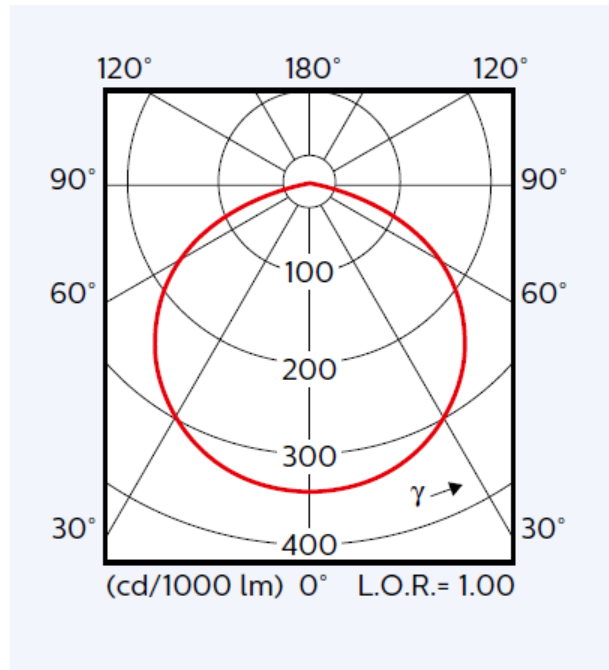

CoB with a standard/ down-light/ Zhaga poke-in holder

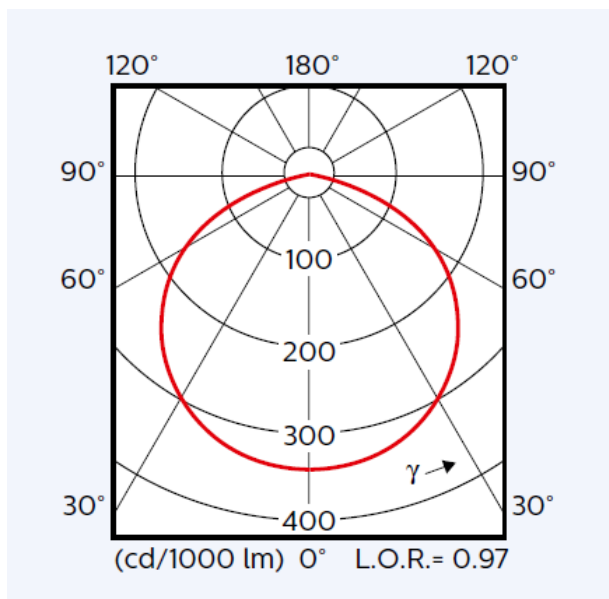

CoB with a poke-in holder

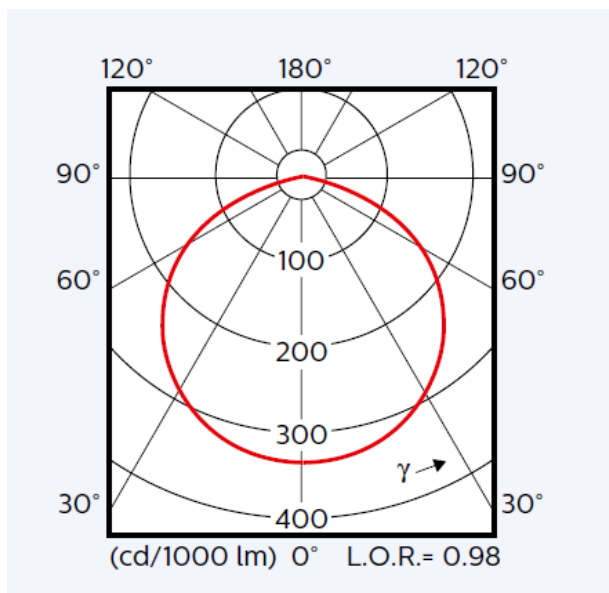

Fortimo SLM C 830 PW 1203 L09 1619 G7
 Fortimo SLM C 930 PW 1203 L09 1619 G7
 Fortimo SLM C 935 PW 1203 L09 1619 G7
 Fortimo SLM C 940 PW 1203 L09 1619 G7

Parameter	Min	Typ	Max	Unit
Forward voltage	32.4	34.4	37.4	V
Power consumption	9.7	10.3	11.2	W

Tuning information

Flux and efficacy versus current (at Tc nominal)

I [mA]	Flux [%]	Efficacy [%]
510	156	87
405	129	93
300	100	100
240	82	104
150	53	112

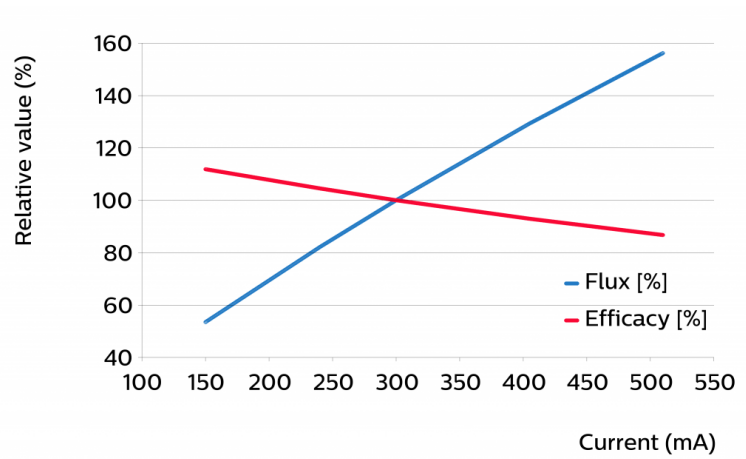

Flux and efficacy versus temperature at Tc (at I nominal)

Tcase [°C]	Flux [%]	Efficacy [%]
95	98	99
85	100	100
25	109	106
0	112	108

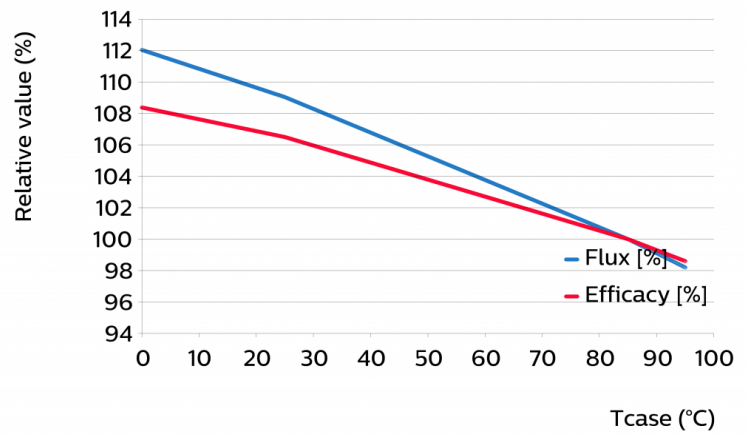

Lumen maintenance

Operation point	Lumen maintenance x 1000 hours	L70			L80			L90		
		B50	B20	B10	B50	B20	B10	B50	B20	B10
80% Inom 240 mA	Tc 65°C	>50	>50	>50	>50	>50	>50	>50	>50	42
	Tc nom 85°C	>50	>50	>50	>50	48	39	35	23	18
	Tc max 95°C	>50	>50	42	>50	33	27	24	16	13
Inom 300 mA	Tc 65°C	>50	>50	>50	>50	>50	>50	>50	47	38
	Tc nom 85°C	>50	>50	>50	>50	44	35	32	21	17
	Tc max 95°C	>50	49	39	46	30	24	22	14	12
Ilife 510 mA	Tc 65°C	>50	>50	>50	>50	>50	>50	50	33	26
	Tc nom 85°C	>50	>50	41	48	32	25	23	15	12
	Tc max 95°C	>50	35	28	34	22	18	16	10	8

Lifetime

Parameter	Value	Unit
C10 at Tc life	50000	hours

Please refer to the performance window to ensure that your operating conditions are covered.

>50 k hours claim is based on extrapolating raw LM80-data by using statistical techniques.

Switching cycles in accordance to EU 1194/2012: >15000.

Mechanical characteristics

Fortimo SLM C 830 PW 1203 L09 1619 G7

Fortimo SLM C 930 PW 1203 L09 1619 G7

Fortimo SLM C 935 PW 1203 L09 1619 G7

Fortimo SLM C 940 PW 1203 L09 1619 G7

Parameter	Min	Typ	Max	Unit
Length	18.8	19	19.2	mm
Width	15.8	16	16.2	mm
Height PCB	0.9	1	1.1	mm
Height including dam	1.2	1.5	1.8	mm

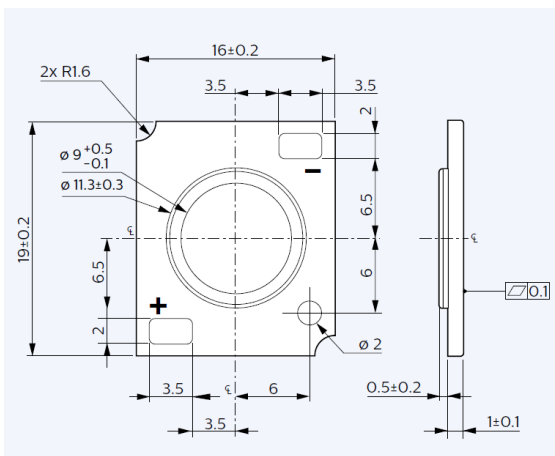

Absolute ratings

Parameter	Min	Typ	Max	Unit
Current through the LED module (I-max)			510	mA
Case temperature (Tc-max)			95	°C
Power at rated Vf-max and I-max			20.1	W
ESD (direct contact)			8	kV
Ambient temperature	-20		40	°C
Storage temperature	-40		80	°C

Application information

Certificates and Standards

IEC 62031:2008 (First Edition) + A1:2012 + A2:2014

EN 62031:2008 (First Edition) + A1:2013 + A2:2015

Relevant clauses of IEC 62471:2006 (Incl. IEC/TR 62471-2: 2009 and IEC/TR 62778: 2014)

Relevant clauses of IEC 60838-1:2004 + A1:2008 + A2:2011 with IEC 60838-2-2:2006 + A1:2012

Relevant clauses of EN 62471:2008 (With IEC/TR 62471-2: 2009 and IEC/TR 62778: 2014)

Relevant clauses of EN 60838-1:2004 + A1:2008 + A2:2011 with EN 60838-2-2:2006 + A1:2012

UL 8750

ENEC+

CE

Environmental

RoHS/REACH

Application

IP rating	No IP-rating
Overheating protection	No
Luminaire class	IEC Class I and Class II
Dimming	Yes

Performance Window

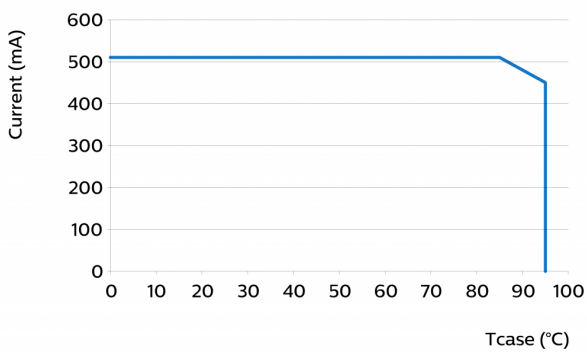



© 2018 Philips Lighting Holding B.V. All rights reserved.

This document contains information relating to the Philips Lighting portfolio, intended for companies who may be interested in developing their product offering. Note that the information provided is subject to change. Philips Lighting does not give any representation or warranty as to the accuracy or completeness of the information included herein and shall not be liable for any action in reliance thereon. The information presented in this document is not intended as any commercial offer and does not form part of any quotation or contract.

www.philips.com/technology

03/2018